

Feeders

Model TR-MS3



Instructions for use

Original version in Italian
Second edition – January 2021

Document code
LMC3EN002

All rights reserved. The user is not allowed to reproduce, store in a filing system or transmit in any form or by any means, such as a mechanical, photocopying, recording or other system, any part of this publication without the prior written consent of Ragazzini S.r.l. Short excerpts appearing in articles in specialised publications are exempt from the above prohibitions.

ragazzini **rotho** and **rotho·Noxys** are trademarks registered by Ragazzini S.r.l.

The logos  and  are owned by Ragazzini S.r.l.

TABLE OF CONTENTS

A	CHARACTERISTIC DATA – MACHINE CONFIGURATION	(attached to the machine)	
B	GENERAL WARNINGS		5
B.1	RESPONSIBILITY		6
B.2	ORIGINAL VERSION OF THE INSTRUCTIONS		6
B.3	CONFORMITY OF THE PRODUCT		6
B.3.1	<i>COPY OF THE EC DECLARATION OF CONFORMITY</i>		7
B.3.2	<i>IDENTIFICATION PLATE</i>		8
B.4	EXPLANATION OF THE SYMBOLS AND PICTOGRAMS USED IN THE MANUAL		9
B.4.1	<i>WARNING NOTES</i>		9
B.4.2	<i>HAZARD PICTOGRAMS THAT MAY BE PRESENT IN THE INSTRUCTIONS FOR USE</i>		9
C	SAFE INTERACTION WITH THE MACHINERY		10
C.1	WORK ENVIRONMENT		10
C.2	MAN-MACHINE INTERFACES		10
C.3	INTENDED USE OF THE FEEDER, STANDARD VERSION		10
C.3.1	<i>INTENDED USE OF THE MACHINE</i>		10
C.3.2	<i>PROHIBITED USE</i>		10
C.3.3	<i>REASONABLY FORESEEABLE MISUSE OF THE MACHINE</i>		10
C.4	GUARDS AND SAFETY DEVICES		11
C.4.1	<i>ELECTRICAL SAFETY DEVICES</i>		11
C.4.2	<i>SAFETY FUNCTIONS ACCORDING TO THE EN13849-1 STANDARD</i>		11
C.4.3	<i>MEASURES TO REDUCE NOISE RISKS</i>		11
C.4.4	<i>MEASURES TO REDUCE EXTREME TEMPERATURES RISKS</i>		11
C.4.5	<i>MEASURES TO REDUCE OTHER RISKS</i>		11
C.5	RESIDUAL RISKS		12
C.5.1	<i>RESIDUAL RISKS DURING NORMAL USE OF THE MACHINE</i>		12
C.5.2	<i>RISKS GENERATED BY TAMPERING AND/OR PROHIBITED BEHAVIOUR</i>		12
C.5.3	<i>RESIDUAL RISKS DURING MAINTENANCE</i>		12
C.5.4	<i>DANGEROUS AREAS</i>		13
C.5.5	<i>RISKS FOR EXPOSED PERSONS</i>		13
C.5.6	<i>INFORMATION AND WARNINGS APPLIED ON THE MACHINE</i>		13
C.6	PROTECTIVE MEASURES TO BE TAKEN BY THE USER		14
C.6.1	<i>PERSONAL PROTECTIVE EQUIPMENT</i>		14
D	GENERAL DESCRIPTION		15
D.1	FEEDING FEEDER FOR ROTHO PERISTALTIC PUMP		15
D.2	THEORY OF OPERATION		15
D.3	DIMENSIONS AND VOLUME		16
E	TRANSPORTATION - HOISTING - STORAGE		17
E.1	GENERAL WARNINGS		17
E.2	PERSONAL PROTECTIVE EQUIPMENT		17
E.3	TRANSPORTATION		18
E.4	LIFTING AND HANDLING THE MACHINE		18
E.5	STORAGE		18
F	INSTALLATION		19
F.1	GENERAL WARNINGS		19
F.2	PERSONAL PROTECTIVE EQUIPMENT		19
F.3	OPERATION AND MAINTENANCE AREAS		19
F.4	CHECKS BEFORE INSTALLATION		20
F.5	ELECTRICAL CONNECTION		20
F.6	CONNECTION WITH PRODUCT RECEIVING SYSTEM		20
F.6.1	<i>CORRECT CONNECTION TO THE PROCESSING LINE</i>		20
F.6.2	<i>CONNECTING THE FEEDER TO THE PUMP</i>		21
G	INSTRUCTIONS FOR COMMISSIONING - OPERATION - SHUT-DOWN		22
G.1	GENERAL WARNINGS FOR NORMAL OPERATION OF THE MACHINE		22
G.1.1	<i>CHECKS AND INSPECTIONS FOR THE SAFE USE OF THE MACHINE</i>		22
G.2	PERSONAL PROTECTIVE EQUIPMENT		23
G.3	EMERGENCY STOP		23
G.4	START		23
G.5	OPERATION		23
G.5.1	<i>ACTIONS TO BE AVOIDED</i>		24
G.6	STOPPING		24
G.6.1	<i>FEEDER DRAINAGE</i>		24
G.6.2	<i>FEEDER CLEANING</i>		24
G.7	COMPLIANCE WITH HYGIENE REQUIREMENTS		25
G.7.1	<i>DRAINAGE</i>		25
G.7.2	<i>CLEANING</i>		25
G.8	RESIDUAL RISKS		25
H	TROUBLESHOOTING		26
I	MAINTENANCE		27
I.1	GENERAL WARNINGS		27
I.2	PRECAUTIONS AND WARNINGS WHEN PREPARING THE MACHINE FOR ROUTINE MAINTENANCE		27
I.3	PERSONAL PROTECTIVE EQUIPMENT		28
I.4	PROCEDURES FOR PLACING THE MACHINE IN MAINTENANCE STATUS		28
I.5	NORMAL WEAR PARTS		29
I.5.1	<i>REPLACEMENT OF THE SEAL</i>		29
I.6	GEARBOX		30

I.7	MOTOR	30
J	SPARE PARTS	31
J.1	HOW TO ORDER SPARE PARTS	31
J.2	SPARE PARTS ORDER EXAMPLE	31
J.3	SPARE PARTS LIST	32
K	DEMOLITION AND DISPOSAL	33
K.1	GENERAL WARNINGS CONCERNING DEMOLITION AND DISPOSAL OF THE MACHINE	33
K.1.1	<i>SPECIAL AND HAZARDOUS WASTE</i>	33
K.2	PERSONAL PROTECTIVE EQUIPMENT REQUIRED DURING MACHINE DEMOLITION AND DISPOSAL	33
K.3	MACHINE DISMANTLING	33
K.4	SORTING THE MATERIALS	34
K.5	DISPOSING OF MACHINE MATERIALS AND PRODUCTS	34
L	OPTIONAL EQUIPMENT OF THE FEEDER	35

B GENERAL WARNINGS

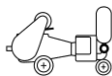
- Carefully read the manual before starting any operation.
- The machine must be used as supplied by Ragazzini S.r.l., following all the instructions and indications given in this manual.
- The necessary spare parts for each component will be supplied by Ragazzini S.r.l.; otherwise, we decline any kind of responsibility for the product and/or for the damage it may cause.
- These instructions contain useful information for training and informing the operator, in order to avoid improper and dangerous use of the machine.
- The instructions must be integrated by the legislative provisions and technical standards in force; they do not replace any system regulations and any additional prescriptions, even non-legislative, which have been issued in any case for safety purposes.
- The instructions for use are an integral part of the machine; it is necessary to keep them in good condition, in a safe place and available to the operator (or anyone who requests them, as long as this person is authorised to use the machine) for the entire productive life of the machine.
- In the case of sale, rental, use or financial leasing of the machine, the instructions must be attached to the machine.
- The employer (or their representative) must have the operators read the contents of these instructions.
- Unfamiliarity with the information and warnings given in this manual can lead to situations of risk for the health and safety of operators.
- The operator must comply with the warnings and procedures set down in these instructions in all stages of the machine's life cycle.
- Feeders are machines that present dangerous parts as they are under tension and equipped with movement. Therefore:
 - Any improper use
 - The removal of the protections and/or the disconnection of the protection devices
 - The lack of inspections and maintenanceCan cause serious damage to people or things.
- If the operator detects discrepancies between what is described in this document and the machine, they must immediately inform their supervisor¹ without using the machine: incorrect or rash manoeuvres can be a source of danger to the health of the operator and/or the people who are near the machine.
- The safety manager must ensure that the machine is handled, installed, commissioned, used, serviced and repaired exclusively by qualified personnel who must therefore have:
 - Specific technical training and experience.
 - Knowledge of technical standards and applicable laws.
 - Knowledge of the general national, local and plant safety requirements.
- The machine is intended to be part of an industrial plant. It is the customer's responsibility (through their Health and Safety Manager) to guarantee overall safety and carry out the analysis of the risks associated with the interfacing with other plant components.
- Adopt the necessary additional protection measures and related signs.
- The following works cannot be carried out without the authorisation of the Health and Safety Manager:
 - Installation
 - System modifications (configuration or intended use)
 - Interventions on the electrical parts of the machine.

¹ Supervisor: they represent the operational function, the person who has a good knowledge of the workplace and its occupants, who supervises the work activities and ensures that the instructions given are observed. They have duties of surveillance and supervision of the instructions given.

B.1 RESPONSIBILITY

The manufacturer Ragazzini S.r.l. is not responsible for:

- Improper use of the machine or its use for purposes other than those envisaged;
- Failure to comply with the instructions for use and maintenance provided by Ragazzini S.r.l.;
- Failure to comply with the regulations and safety measures contained in this manual and/or in the supplementary documentation provided;
- Any tampering, replacement or modification (not authorised in writing by the manufacturer Ragazzini S.r.l.) of one or more parts of the machine;
- Any intervention that is not part of ordinary maintenance.

Therefore, Ragazzini S.r.l. is not responsible for any direct or indirect damage deriving from failure to comply with the above-mentioned indications.

B.2 ORIGINAL VERSION OF THE INSTRUCTIONS

This document was originally issued in Italian.

In the event of disputes due to translated versions, even if provided by Ragazzini S.r.l., the only valid text shall remain solely and exclusively the original Italian version.

B.3 CONFORMITY OF THE PRODUCT

The machine described in these instructions was designed and built to be installed in a plant with industrial characteristics.

The machine is marketed with EC declaration of conformity pursuant to directive 2006/42/EC, annex II, point 1 A.

Any modification that alters the design and construction characteristics of the machine in terms of the place of use and of safety and risk prevention, may only be carried out by the manufacturer, who will subsequently certify its compliance with the safety standards in force.

Any changes in location, modifications or maintenance operations not contemplated in this document are to be considered unauthorised.

Under no circumstance will Ragazzini S.r.l. be held responsible in case of non-compliance with the above safety dispositions.

B.3.1 Copy of the EC declaration of conformity

**DICHIARAZIONE  DI CONFORMITÀ
di una macchina**

(2006/42/CE, All. II, p. 1, let. A)

EC Declaration of conformity, Déclaration CE de conformité, Declaración CE de conformidad, EG-konformitätserklärung, Declaração CE de conformidade

*Il fabbricante e Nome e indirizzo della persona autorizzata a costituire il fascicolo tecnico:
The manufacturer and name and address of the person authorised to compile the technical file
La fabricant et le nom et l'adresse de la personne autorisée à constituer le dossier technique
La fabricante y nombre y dirección de la persona facultada para elaborar el expediente técnico
Die Hersteller und Name und Anschrift der Person, die bevollmächtigt ist, die technischen Unterlagen zusammenzustellen
O fabricante e Nome e endereço da pessoa autorizada a compilar o processo técnico*

Ragazzini S.r.l.

Sede legale:
Via A. Volta 8
48018 Faenza (RA) - Italy

Dichiara che la macchina:

declares that the machine, déclare que la machine, declara de que la máquina, erklärt dass die Maschine, declara que a máquina

Tipo – type - son type – tipo – typ – tipo:	Tramoggia
Modello – model - son modèle – modelo – modell - modelo:	TR-
Numero di serie - serial number - son numéro de série - número de serie - Seriennummer - número de serie:	
Funzione – function – fonction – función – funktion - função:	Alimentazione prodotti
Anno di costruzione - year of construction - année de construction - año de construcción - baujahr - ano de construção:	2015

è conforme a tutte le disposizioni pertinenti delle seguenti direttive comunitarie:
fulfils all the relevant provisions of the following directives:
satisfait à l'ensemble des dispositions pertinentes des directives suivantes
cumple todas las disposiciones aplicables de las siguientes directivas comunitarias
allen einschlägigen Bestimmungen Folgende Richtlinien entspricht
satisfaz todas as disposições relevantes das seguintes directivas

2006/42/CE

e alle seguenti norme armonizzate, norme e/o specifiche tecniche applicate:
and under the following harmonised standards, technical standards and/or specifications used:
et la suivante normes harmonisées, normes et/ou spécifications techniques qui ont été utilisées:
y la siguiente normas armonizadas, normas y/o especificaciones técnicas que se hayan utilizado:
und die folgende harmonisierten Normen, technischen Normen und/oder Spezifikationen angewandt:
e a seguir normas harmonizadas, normas e/ou especificações técnicas que tiverem sido utilizadas:

EN ISO 12100:2010

Luogo-Place-Lieu-Lugar-Ort-Local: **Faenza (RA)**
Data-Date-Date-Fecha-Datum-Data: **26/11/2018**

RAGAZZINI S.r.l.

Zaffagnini Alberto
Legale Rappresentante

B.3.2 Identification plate

The machine is identified by the type, serial number and year of construction marked on the identification plate applied on the machine.

The following warnings must be respected at all times:

- Never remove the identification plate from the original position chosen by the machine manufacturer;
- Do not alter or falsify the technical information on the plate;
- Do not clean the plate using abrasive tools (such as steel brushes) to avoid making the information illegible.



PLEASE NOTE: All the data marked on the plate must always be legible. Refer to the identification data in all communications with the manufacturer, e.g., requests for replacement parts, information, and technical assistance. If the plate deteriorates with use and is no longer legible, even in only one of its elements, another one must be requested from the manufacturer, by referring to the data contained in this manual or on the original plate.

B.4 EXPLANATION OF THE SYMBOLS AND PICTOGRAMS USED IN THE MANUAL

B.4.1 Warning notes

Warnings relating to possible risks to the health and safety of the operator are highlighted with warning notes accompanied by the relative hazard pictogram (see paragraph B.4.2 “Hazard pictograms that may be present in the instructions for use”); the text of the note is highlighted with a yellow background.

Below is an example of a warning note:







MOVING PARTS HAZARD: It is forbidden to remove or tamper with the guards.	
--	---

Instructions whose non-fulfilment compromises the correct operation of the machine are highlighted as follows:

Note text	
-----------	---

B.4.2 Hazard pictograms that may be present in the instructions for use

This manual contains the following hazard pictograms:

	DANGER		ELECTROCUTION		MOVING PARTS
	HANGING LOADS		HIGH TEMPERATURE		DANGEROUS SUBSTANCES

C SAFE INTERACTION WITH THE MACHINERY

C.1 WORK ENVIRONMENT

Refer to the customer's production line.

C.2 Man-machine interfaces

Refer to the manual of the Ragazzini peristaltic pump associated for information on the commands to be used by the operator, if present.

C.3 INTENDED USE OF THE FEEDER, STANDARD VERSION

C.3.1 Intended use of the machine

The Feeder must be connected only and exclusively to the associated peristaltic pump manufactured by Ragazzini S.r.l.

The family of Feeders for peristaltic pumps has been designed and built by Ragazzini S.r.l. to rearranging and bringing the product closer to the suction section of the pump. Dry running (empty pump) does not cause any damage to the system.

Environmental limits of the machine:

- Ambient temperature: between -10°C and 40°C.
- Work environment: indoor or outdoor with protection from sunlight and bad weather.
- Lighting: The area of installation must be sufficiently lit (minimum 200 lux).

ANY OTHER USE DIFFERENT FROM THE ONE DESCRIBED IS NOT ALLOWED BY THE MANUFACTURER.

C.3.2 Prohibited use.

The equipment must not be used:

- To process materials other than those foreseen for the peristaltic pump to which it is associated (see the relative manual).
- Connected to an external power outlet other than the one of the pump to which it is associated.
- For operations other than those described under paragraph C.3.1 "Intended use of the machine".
- In open environments or in closed places without a lightning protection system.
- With direct exposition to sunlight.

Restrictions on the use of the machine:

It is forbidden to:

- Use the machine in a configuration other than the one envisaged by the manufacturer.
- Use the machine in places subject to the risk of explosion and/or fire (the machine is not certified according to the 2014/34/EU ATEX directive).
- Use the machine with fluids at temperatures above the maximum permissible temperatures for the suction hose of the associated peristaltic pump.
- Use the machine with products containing suspended solids bigger than 45% of the internal diameter of the tubular element of the associated peristaltic pump.
- Integrate other systems and/or equipment not foreseen by the manufacturer in the design.
- Remove components and parts of the machine.
- Perform interventions when the machine is stopped but before disconnecting the electrical power supply. The machine could receive a remote ("auto") consent signal and could restart suddenly.
- Move the machine, when connected to the electric power supply.

C.3.3 Reasonably foreseeable misuse of the machine

It is forbidden to:

- Tamper with the machine or its safety devices;
- Tamper with the movable and/or fixed guards;
- By-pass the safety devices;
- Climb onto and/or walk on the machine.

C.4 GUARDS AND SAFETY DEVICES

The Health and Safety Manager of the workplace in which the machine is used, after having performed the risk analysis and based on the conditions of use of the Feeder in the destination line, is responsible of having an extension installed on the edge of the product collection tank to prevent the operator from coming into contact with moving parts (see paragraph F.6 “CONNECTION WITH PRODUCT RECEIVING SYSTEM”). This protection can also be requested from the manufacturer.

A danger warning strip has been applied to the Feeder with the obligation to read this manual (see paragraph C.5.6 “Information and warnings applied on the machine”).

MOVING PARTS HAZARD: It is forbidden to remove or tamper with the guards.	
--	---

C.4.1 Electrical Safety Devices

There are no direct control systems on the Feeder manufactured by Ragazzini S.r.l., as the machine is designed to be connected directly to the electrical panel of the pump to which it is associated and from which it receives the power supply. The main safety device is the emergency switch located on the electrical panel of the associated peristaltic pump.

ELECTROCUTION HAZARD: In case of fire in the vicinity of the machine (or on the machine itself), the use of water or other aqueous/humid extinguishing agents is prohibited, as this presents a risk of electrocution due to indirect contact.	
---	---

C.4.2 Safety functions according to the EN13849-1 standard

The safety functions implemented on the machine² are listed below:

Name of the safety function	PL ³
Stopping of the Feeder upon pressing the emergency button	c
Feeder stops due to tubular element rupture sensor trip	c
Feeder stops due to opening of the mobile guard (optional RRA configuration)	c

C.4.3 Measures to reduce noise risks

Refer to the manual of the peristaltic pump to which the Feeder is associated.

C.4.4 Measures to reduce extreme temperatures risks

HIGH TEMPERATURE HAZARD: in case of pumping fluids with a constant temperature higher than 60°C it is necessary to provide suitable signs or shielding.	
--	---

C.4.5 Measures to reduce other risks

HAZARD: The machine is not equipped with lightning protection and must be installed in lightning protected sites.	
--	---

² The definition of safety function is given in the UNI EN ISO 13849-1 standard; a safety function is a function of the machine whose failure can lead to an immediate increase in the risk related to the machine itself.

³ PL (Performance Level): in the UNI EN ISO 13849--1 standard the *Performance Level* is defined as a discrete level used to specify the ability of safety-related control parts to perform a safety function under the intended conditions. 5 values are assigned to the Performance Level, from PL_a to PL_e as the risk increases (PL=e > PL=d > PL=c > PL=b > PL=a).

C.5 Residual risks

<p>HAZARD: Carefully read the “Residual Risks” section of the associated peristaltic pump manual.</p>	
--	---

Risks deriving from:

- Inattention of the operator,
- Failure to comply with the information and warnings contained in this manual,
- Unauthorised uses of the machine;

Cannot be totally eliminated by an inherently safe design, due to the machine construction type.

Information on the residual risks existing despite adopting the protection measures described in this manual are described below.

C.5.1 Residual risks during normal use of the machine

During the normal operation of the machine there are no dangers for the operator if the guards and protections (see paragraph F.6 “CONNECTION WITH PRODUCT RECEIVING SYSTEM”) are intact and correctly installed, as the movements that entail a hazard condition are enclosed within the guards.

C.5.2 Risks generated by tampering and/or prohibited behaviour

Following tampering of the protection devices (fixed guards) and subsequent start-up of the machine, the following residual risks connected to hazards of a mechanical nature will be present:

List of hazards		Identification of the dangerous situation			Detailed description of the risk
Type or group	Origin	Potential consequences	Dangerous area	Phase of the life cycle	
Mechanical	Approaching of moving parts to fixed parts	Dragging or entrapment	Machine area	Installation Maintenance Operation	Risk of dragging and entrapment due to uncovered moving parts of the machine (conveyor screw)
Mechanical	Moving parts	Dragging or entrapment Crushing Shearing Projection of objects	Machine area	Production Maintenance Adjustment	Risk of contact between moving parts of the machine (conveyor screw, driveline components, motor, gear unit) and parts of the operator's body
Mechanical	Rotating parts	Dragging or entrapment	Machine area	Production Maintenance Adjustment	Risk of contact between moving parts of the machine and the operator's body

Another source of risk for the operator caused by prohibited behaviour can arise due to failure to use adequate PPE (Personal Protective Equipment).

C.5.3 Residual risks during maintenance

During machine maintenance, the possibility of injury is reasonably foreseeable:

- To the upper limbs (abrasion against mechanical parts),
- To the lower limbs (fall of mechanical parts if not adequately supported),
- To the eyes (dangers generated by pressurised fluids and live elements),
- To the head (contact with machine parts).

C.5.4 Dangerous areas

Based on the above considerations, the following are to be considered dangerous areas:

- The area inside the machine, during execution of the production cycle with guards tampered with or removed;
- (Optional pump configuration with electrical panel) the space alongside electrical panels with door open and power connected, during troubleshooting operations.

C.5.5 Risks for exposed persons

Exposed persons are people not involved in the operation of the machine, therefore other people working in the company or visitors.

These instructions do not deal with problems external to the company using the machine: in this sense, a person standing in an area close to the company premises is not considered an exposed person.

In this type of machine there are no risks for exposed persons during operation (with the door of the electrical panel closed and the machine in its full safety condition).

<p>WARNING: NO ACCESS TO UNAUTHORIZED PERSONNEL</p> <p>During normal operation, keep exposed persons at a safe distance from dangerous areas. During maintenance: it is absolutely forbidden to let people go near the machine. It is recommended to fence off the entire external perimeter area of the machine, also displaying, if necessary, the sign “MACHINE UNDER MAINTENANCE”.</p>	
---	---

C.5.6 Information and warnings applied on the machine

Following the identification of some residual risks, some warning signs have been installed on the machine, which have been defined in accordance with the European and international standards relating to graphical hazard symbols to be used on systems (EN ISO 7010).

The Customer must immediately replace any warning plate that, as a result of wear, has become illegible. The warning plates applied on the machine are the following:

Prohibition to remove guards
(Applied to the pump model associated with the Feeder)



Obligation to read the instructions for use
(Applied to the pump model associated with the Feeder)



<p>WARNING:</p> <p>It is absolutely forbidden to remove the warning plates applied on the machine.</p> <p>Ragazzini S.r.l. declines all liability as far as the machine safety is concerned in the event of non-compliance with this prohibition.</p>	
---	---

Applied on the strip to be removed only after installation (to be carried out according to the instructions and warnings given in this manual). See paragraph F.6 “CONNECTION WITH PRODUCT RECEIVING SYSTEM”.







<p>WARNING:</p> <p>The customer, after removing the strap, assumes responsibility for having read and understood this manual, for complying with all the requirements, in particular with the requirements indicated in paragraphs C and F.</p> <p>Ragazzini S.r.l. declines all liability as far as the machine safety is concerned in the event of non-compliance with the requirements.</p>	
--	---

C.6 Protective measures to be taken by the user

C.6.1 Personal Protective Equipment

To safeguard the operator's health in the various stages of the machine's life cycle, it is mandatory to use (or have available) the PPE (Personal Protective Equipment) mentioned below. The manufacturer obliges the Customer to use the machine with PPE compliant with the directive on Personal Protective Equipment duly provided with the CE marking. The operator must comply with the directive that defines the methods of use of personal protective equipment during work. Since it is impractical to predict all possible machine operating conditions, the PPE listed refer only to the use of the machine: the employer must prescribe the use of any additional PPE required in compliance with the actual situation in their production site.

PPE to be used in the various stages of the machine's life cycle			
Pictogram	Description	Stage of the life cycle of the machine	Note
	FOOTWEAR	<ul style="list-style-type: none"> • transportation; • installation; • use; • maintenance; • dismantling and demolition 	Use of safety shoes to avoid the risks generated by falling materials.
	DIELECTRIC FOOTWEAR WITHOUT METALLIC PARTS FOR ELECTRICIANS	<ul style="list-style-type: none"> • maintenance on electrical parts 	Use of insulating footwear to prevent the dangers that can be generated by direct or indirect contacts.
	PROTECTIVE GLOVES	<ul style="list-style-type: none"> • transportation; • installation; • maintenance; • dismantling and demolition 	Gloves for hand protection available in case of manipulation of objects that can cause damage or injuries.
	INSULATING PROTECTIVE GLOVES	<ul style="list-style-type: none"> • maintenance on electrical parts 	Use of insulating protective gloves to prevent the dangers that can be generated by direct or indirect contacts
	HELMET	<ul style="list-style-type: none"> • transportation; • installation; • use; • maintenance; • dismantling and demolition 	Protective helmet to be used during machine hoisting operations to prevent the dangers generated by hanging loads.
	SUITABLE CLOTHING	<ul style="list-style-type: none"> • transportation; • installation; • use; • maintenance; • dismantling and demolition 	Suitable clothing, such as overalls: it is prohibited to wear wide sleeves and/or loosen clothing that could be easily caught in mechanical parts.
	FACE SHIELD	<ul style="list-style-type: none"> • maintenance 	Face protective shield during work on parts of the system and on electrical parts, especially if live.

WARNING: The machine does not exceed the noise level established by law; therefore, hearing protection earmuffs are not mandatory. However, the operator must also carefully evaluate the environment of use: if it is very noisy, protective earmuffs must be used. When using protective earmuffs, the operator must pay even more attention, as one of the senses of perception of danger (hearing) is missing. Observe the surrounding environment well, as the visual perception must compensate for the lacking sense of hearing.



D GENERAL DESCRIPTION

D.1 FEEDING FEEDER FOR ROTHO PERISTALTIC PUMP

The Feeder is composed of the following main elements (picture is indicative only):

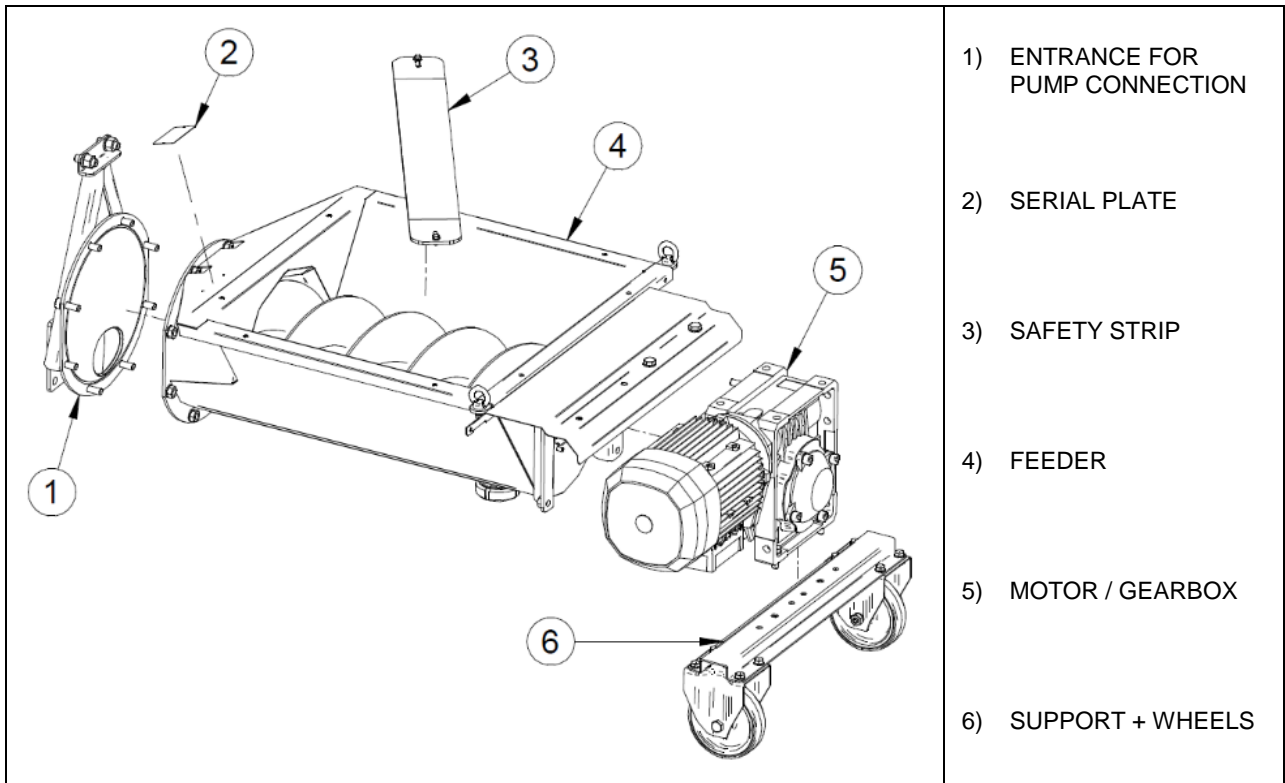

D.2 THEORY OF OPERATION

The feeder screw rearranges the product and brings it closer to the pump suction.

The flow rate is proportional to the conveyor screw rpm.

Dry running (empty pump) does not cause any damage.

D.3 DIMENSIONS AND VOLUME

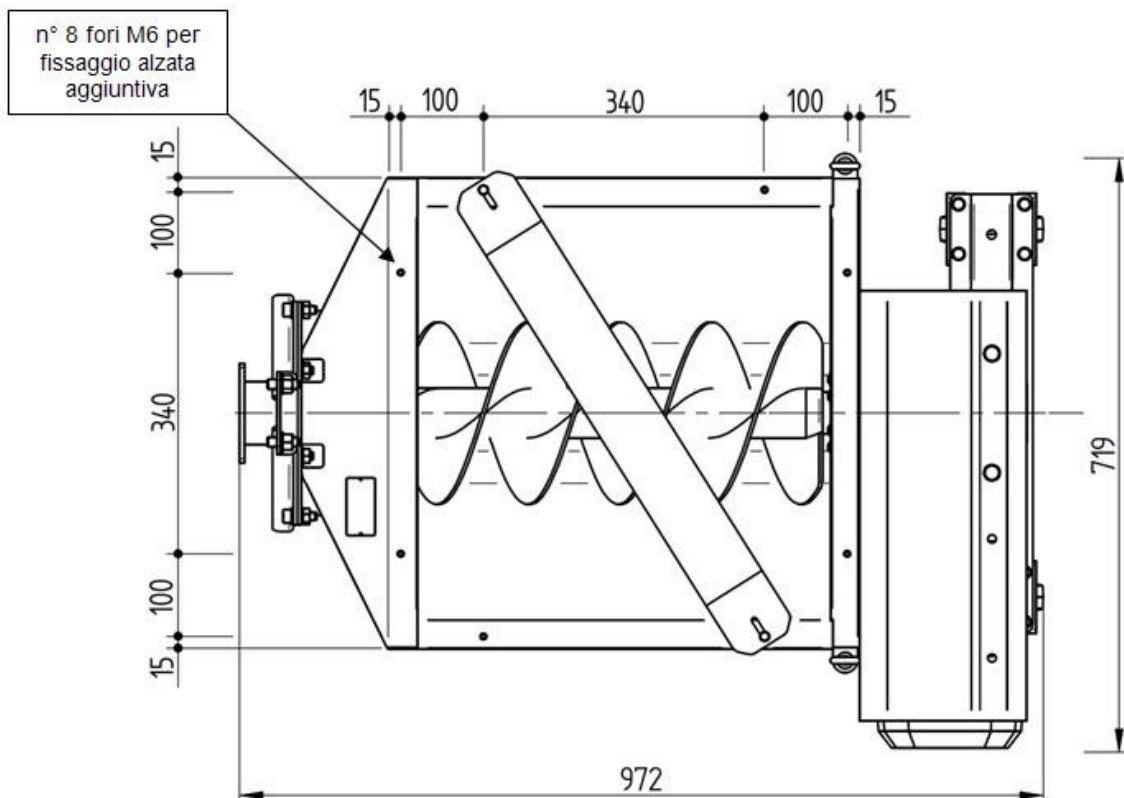
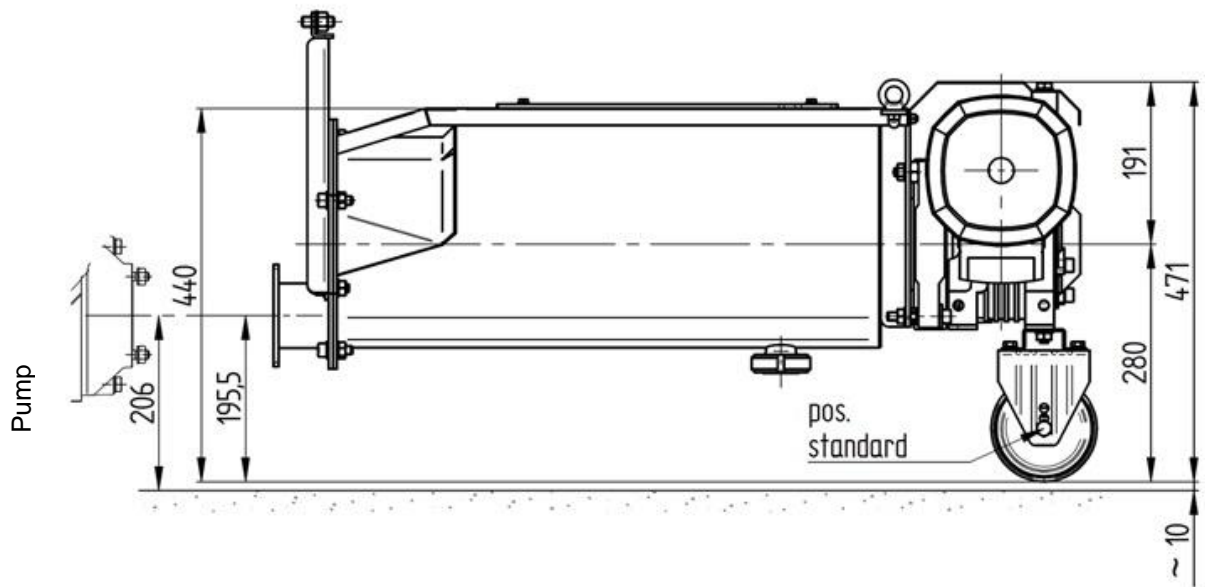

The above images are indicative only; for more details or references to dimensions for specific configurations contact the Technical Service of Ragazzini S.r.l.

E TRANSPORTATION - HOISTING - STORAGE

E.1 GENERAL WARNINGS

The operator responsible for transporting, hoisting and storing the machine must:

- Be a person adequately trained and informed about the work they are about to do;
- Use the personal protective equipment listed in the following paragraph (see paragraph E.2);
- Use suitable equipment to carry out the operations safely and check that such equipment is in perfect condition;
- Use all service equipment as intended by their respective manufacturers.

Before handling the machine, it is necessary to check the capacity and efficiency of the lifting means:

<p>HAZARD: To hoist the machine or some parts of it, it is necessary to use means with a minimum capacity greater than the declared weight of the machine (about 80 kg, safety extension by the customer excluded).</p>	
--	---





Carry out hoisting and transport operations bearing in mind the following warnings:

<p>HANGING LOAD HAZARD During the hoisting operations make sure that there are no exposed persons in the area occupied by the machine and in the surrounding areas. Hoisting must be carried out seamlessly (free from abrupt movements). During the hoisting procedures, the machine must always be in a stable and secure position. For better load stability, keep the load as low as possible when moving the machine.</p>	
---	---

<p>During hoisting, avoid sudden movements that could damage to the machine.</p>	
--	---

E.2 PERSONAL PROTECTIVE EQUIPMENT

The operator responsible for transporting, hoisting and storing the feeder must use the following personal protective equipment:

Pictogram	Description	Note
	FOOTWEAR	Use of safety shoes to avoid the risks generated by falling materials.
	PROTECTIVE GLOVES	Gloves for hand protection available in case of manipulation of objects that can cause damage or injuries.
	HELMET	Protective helmet to be used during machine hoisting operations to prevent the dangers generated by hanging loads.
	SUITABLE CLOTHING	Suitable clothing, such as overalls: it is prohibited to wear wide sleeves and/or loosen clothing that could be easily caught in mechanical parts.

E.3 TRANSPORTATION

The feeder must be handled by means of a suitable mechanical hoisting device.

The feeder is protected by a packaging consisting of a rigid bottom (pallet) and a cardboard casing.

The materials that make up the packaging are recyclable.



E.4 LIFTING AND HANDLING THE MACHINE

The machine must be moved and lifted by means of an overhead travelling crane or a jib crane.

To lift the feeder, where needed, use the eyebolts with which it is equipped.

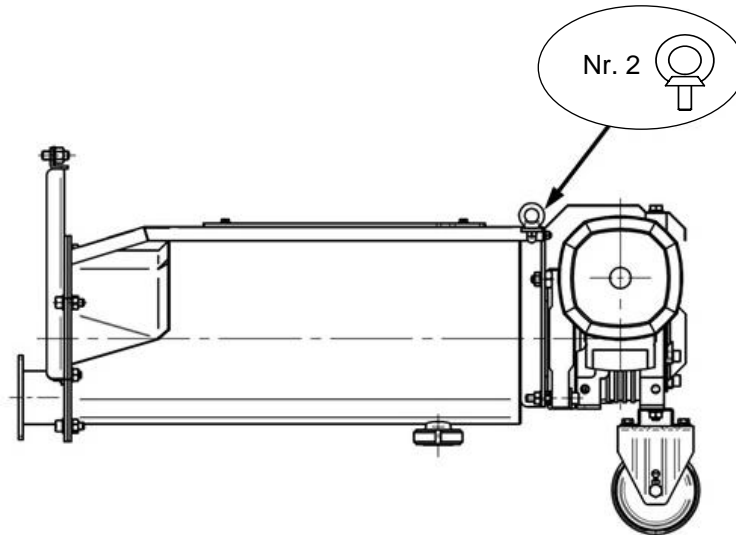

The wheels supplied are suitable for short movements of a few meters only, to facilitate connection and disconnection to the associated pump.

Once the machine has been connected, the wheels are not in contact with the ground.

E.5 STORAGE

Do not store the machine outdoor, in areas exposed to bad weather or very humid.

For storage periods longer than 60 days, carefully clean the feeder.

F INSTALLATION

WARNING: Carefully read the “Installation” section in the associated peristaltic pump manual.	
--	---





F.1 GENERAL WARNINGS

The operator responsible for machine installation must:

- Be a person adequately trained and informed about the work they are about to do;
- Use the personal protective equipment listed in paragraph F.2;
- Use suitable equipment to carry out the operations safely and check that such equipment is in perfect condition;
- Use all service equipment as intended by their respective manufacturers.

F.2 PERSONAL PROTECTIVE EQUIPMENT

The operator responsible for the installation procedure of the feeder must use the following personal protective equipment:

Pictogram	Description	Note
	FOOTWEAR	Use of safety shoes to avoid the risks generated by falling materials.
	PROTECTIVE GLOVES	Gloves for hand protection available in case of manipulation of objects that can cause damage or injuries.
	HELMET	Protective helmet to be used during machine hoisting operations to prevent the dangers generated by hanging loads.
	SUITABLE CLOTHING	Suitable clothing, such as overalls: it is prohibited to wear wide sleeves and/or loosen clothing that could be easily caught in mechanical parts.

F.3 OPERATION AND MAINTENANCE AREAS

The area chosen for the installation of the machine must be well lit, ventilated, far from heat sources and such as to guarantee the correct operation of the machine, considering in particular access to the controls and to maintenance activities.

The surrounding free space must be 500 ÷ 800 mm.

In case the feeder must be installed outdoor, suitable shelters from direct sun and bad weather must be provided.

HAZARD: The machine is not equipped with lightning protection; therefore, it must be installed in areas protected from this risk.	
---	---

F.4 CHECKS BEFORE INSTALLATION

Once removed from the packaging, check that the machine is free of abrasions or damaged parts.

The materials that make up the packaging are recyclable.



Installation must only be carried out by coupling the feeder to the Ragazzini intended peristaltic pump model.



F.5 ELECTRICAL CONNECTION

To connect the electrical panel of the peristaltic pump to which the feeder is associated, refer to the instructions in the relative instruction manual.

The electrical connection of the feeder to the associated pump takes place by inserting the 6P+T 16A 400V (IEC 61984) watertight mobile plug mounted on the cable of the equipment, in the appropriate socket on the electrical panel of the pump.

ELECTROCUTION HAZARD: Work on electrical parts must be carried out with the machine stopped and disconnected from the electrical supply.



F.6 CONNECTION WITH PRODUCT RECEIVING SYSTEM

MOVING PARTS HAZARD: For the development and installation of specific protections (by the Customer) indicated in paragraph F.6.1 comply with the UNI EN ISO 13857 standard.



The best operation of the feeding feeder for peristaltic pumps is obtained by making the connection with the system in such way that the product is dropped in the furthest area away from the pump.



**F.6.1 Correct connection to the processing line
HERMETIC CONNECTION**

Provide inspection porthole (A) that can only be opened with the appropriate tool.

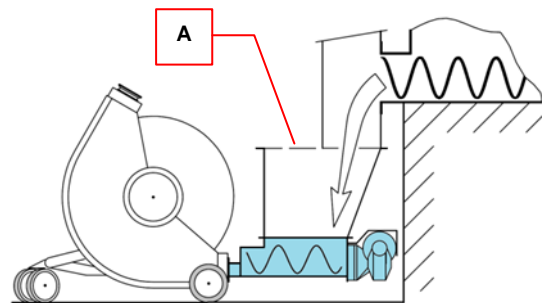

OPEN CONNECTION WITH EXTENSION TO DROP-FEEDING

Assemble an adequate extension to reach height "H" with a sufficient capacity to avoid overflows.

If the height "H" is less than 1600mm, mount a fixed safety net (B) to allow visual control and exclude the possibility of access.

Fit accidental fall protections.

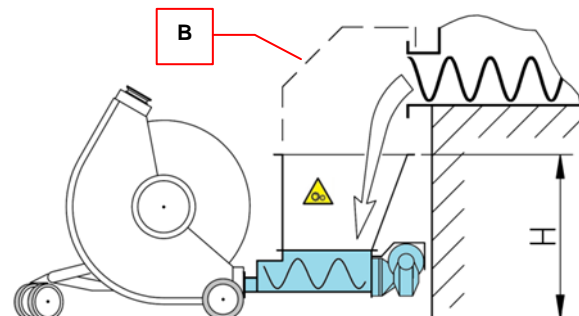

MOVING PARTS HAZARD: display the warning signs on the sides giving access to the feeder.



PUMP WITH FEEDER SERVING DIFFERENT ON-WALL SYSTEMS

Fit an extension (C) and a fixed safety net (D) with mesh ≤50 mm that prevents:

- The possibility of intended or accidental access with parts of the body and with improper tools.
- The accidental fall of the operators.

Prevent operators from entering/exiting the tank opening by climbing on the feeder, even if the power supply of the latter is disconnected.

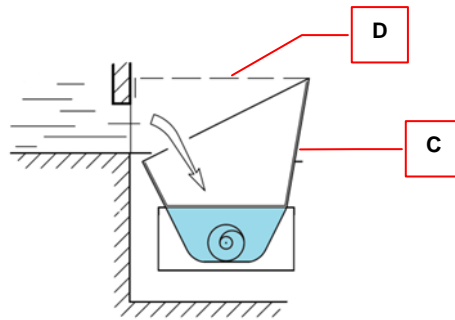

MOVING PARTS HAZARD: display the warning signs on the sides giving access to the Feeder.

F.6.2 Connecting the feeder to the pump

Connecting the feeder to the associated peristaltic pump requires:

- Disassembly of the fittings used for pumping liquid (compensators included).
- Coupling of the feeder to the suction port (see figure), by means of the O-Ring (C) supplied with the pump.
- Fastening the connecting unit first by means of the nuts A, then fasten the square plate by means of the nuts B. When disconnecting the feeder from the pump, first unscrew the nuts (B) of the square plate and the nuts (A) of the connecting unit last.
- The assembly of the upper delivery fitting with increased diameter, which can be adjusted according to the positioning of the delivery pipe.

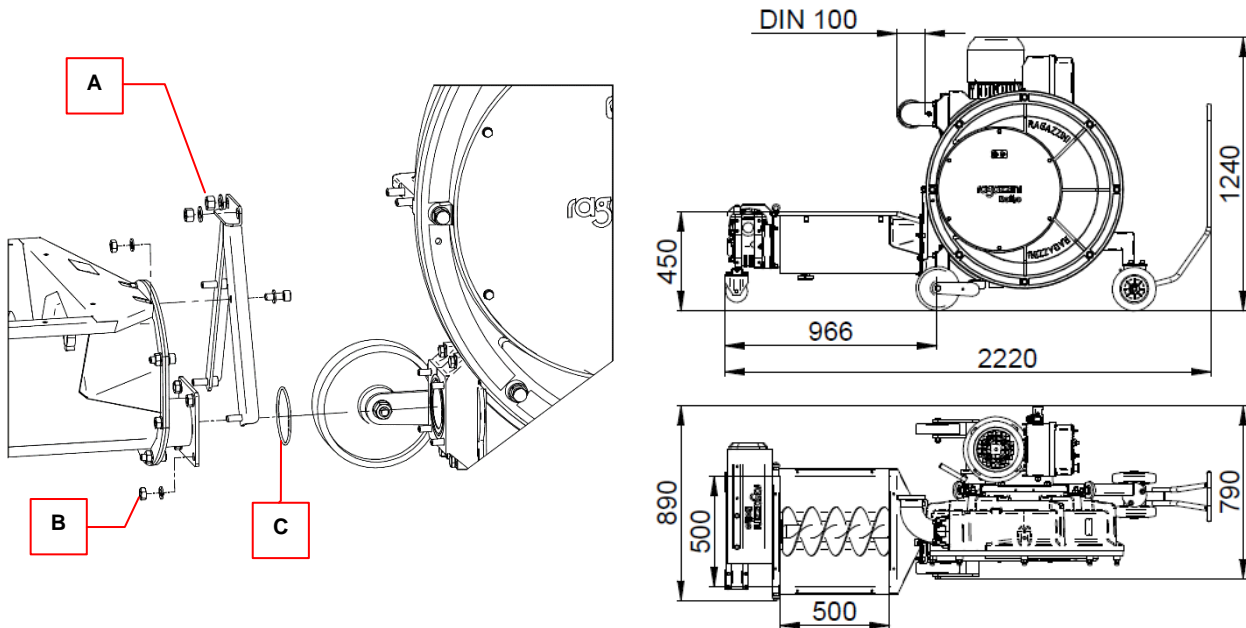

High delivery connection.

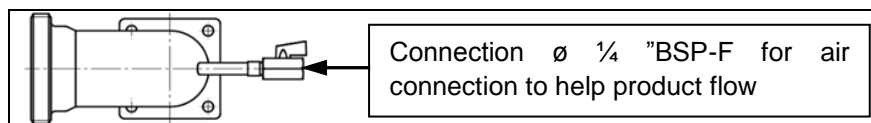

G INSTRUCTIONS FOR COMMISSIONING - OPERATION - SHUT-DOWN

<p>WARNING: Carefully read the section “Instructions for commissioning - Operation - Shut-Down” of the associated peristaltic pump manual.</p>	
---	---

G.1 GENERAL WARNINGS FOR NORMAL OPERATION OF THE MACHINE

The operator must:

- Be trained as required by the laws on safety in the workplace - for Italy see Legislative Decree 81/2008; refer to the laws in force in the Country of the user;
- Be in perfect mental and physical condition, be always alert and with quick reflexes;
- Use personal protective equipment as listed in the following paragraph (G.2);
- Before starting to operate the machine, carry out the checks listed in the following paragraph to ensure that all the safety conditions are met in order to prevent accidents.

The operator must not:

- Tamper with or alter the operation or efficiency of the protection devices installed on the machine.

G.1.1 Checks and inspections for the safe use of the machine

The operator must check:



- That the machine has not been tampered with. If the machine has been altered, it must be put out of service and the supervisor must be notified immediately;
- The general condition of the machine and of its structures: no damage or conditions of evident negligence must be present, especially in relation to ageing, wear and fatigue;
- That the machine bears all the icons and warning plates required, as described in the section “Safe interaction with the machine”;
- That all the control devices are equipped with identification plate.

<p>WARNING: If the machine is damaged or has been modified with respect to its original configuration as established by the manufacturer, it must not be used. Any technical modification affecting the operation or safety of the machine must be carried out exclusively by the manufacturer’s technical personnel or by technicians formally authorised by the manufacturer.</p>	
--	---

<p>WARNING: The preliminary checks must be performed with the machine NOT connected to the electrical supply.</p>	
--	---

G.2 PERSONAL PROTECTIVE EQUIPMENT

The operator responsible for normal operation of the feeder must use the following personal protective equipment:

Pictogram	Description	Note
	FOOTWEAR	Use of safety shoes to avoid the risks generated by falling materials.
	PROTECTIVE GLOVES	Gloves for hand protection available in case of manipulation of objects that can cause damage or injuries.
	SUITABLE CLOTHING	Suitable clothing, such as overalls: it is prohibited to wear wide sleeves and/or loosen clothing that could be easily caught in mechanical parts.

WARNING: The machine does not exceed the noise level established by law; therefore, hearing protection earmuffs are not mandatory. However, the operator must also carefully evaluate the environment of use: if it is very noisy, protective earmuffs must be used. When using protective earmuffs, the operator must pay even more attention, as one of the senses of perception of danger (hearing) is missing. Observe the surrounding environment well, as the visual perception must compensate for the lacking sense of hearing.



G.3 EMERGENCY STOP

Refer to the manual of the peristaltic pump to which the feeder is associated.

G.4 START

Before starting the feeder:

- Perform pre-start checks related to the peristaltic pump to which the feeder is connected.

MOVING PARTS HAZARD

- Make sure the guards protecting the moving parts are fitted.



- Make sure that the feeder is securely connected to the pump and that the direction of rotation of the conveyor screw matches the suction direction of the associated pump.

G.5 OPERATION

- The run, reverse and stop commands are the same of the pump.
- The feeder starts running at the same time as the pump.
- The adjustment of the number of revolutions (flow rate) is proportional to the number of revolutions of the pump.
- Perform some starts and stops, checking the proper operation of the controls and that the connection with the system is liquid-tight (extensions, etc.)





The condition of the stopped system depends on the electrical panel of the pump or on the system; refer to the relevant scenario.

WARNING: Be careful in case of automatic systems and/or remote controls: machines in pause condition could start automatically.



G.5.1 Actions to be avoided

<p>WARNING: At the end of processing, do not leave residual product inside the feeder. Clean at the end of the cycle.</p>	
<p>WARNING: Calibration of motor protections must not be set higher than the plate limits. If the performance of the motor is insufficient, check the system data and contact Ragazzini Technical Service.</p>	
<p>HAZARD: When cleaning the feeder with water jets, do not direct the jet on the motor or electrical equipment. Failure to comply with this disposition can generate an electrocution hazard as well as damage to the electrical equipment.</p>	

G.6 STOPPING

<p>If the feeder stops, it is necessary to first stop the flow of the product to the feeder itself in order to avoid overflows.</p>	
---	---

G.6.1 Feeder Drainage

The feeder is drained through the drain plug located under the tank.
In case of risk of frost, drain the pump at the end of each processing cycle.

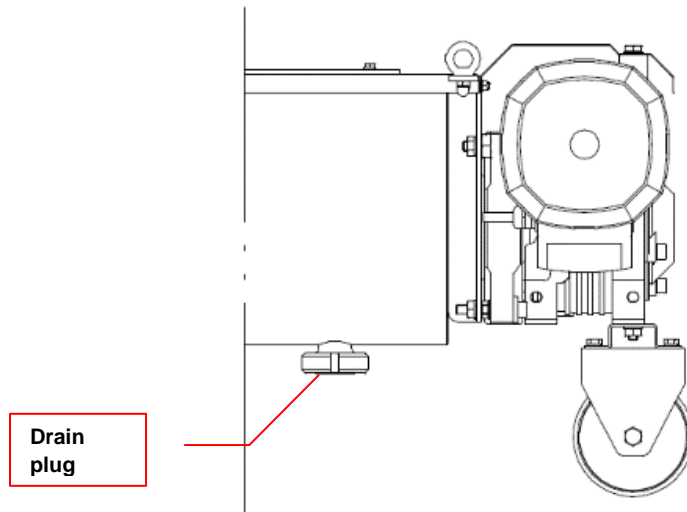

G.6.2 Feeder cleaning

Clean the feeder with fluids which are compatible with the material of the feeder.

G.7 COMPLIANCE WITH HYGIENE REQUIREMENTS

To comply with hygiene requirements (in case of pumping of food fluids) it is necessary to perform the following procedures:

G.7.1 Drainage

To carry out drainage, see the paragraph G.6.1.

G.7.2 Cleaning

The cleaning of the feeder must be carried out:

- Before using the related peristaltic pump.
- At the end of each processing cycle.
- At the end of each maintenance activity performed on the feeder.

The feeder can be sanitized with water at 50 ° C and a 15% caustic soda solution.

G.8 RESIDUAL RISKS

MOVING PARTS HAZARD: The use of the feeding feeder and the need for collection intakes and/or belt conveyors may determine the presence of residual risks related to the access to dangerous areas.

These residual risks can be eliminated providing operators with instructions, with safety maintenance checks and danger signals with adequate warning plates.



H TROUBLESHOOTING

PROBLEMS	CAUSES	SOLUTIONS
THE PRODUCT IS STUCK AND THE PUMP DOES NOT PRIME	The product is too dry.	Add liquid
POOR EFFICIENCY: PRODUCT IN THE FEEDER ACCUMULATES NEAR THE PUMP INLET	Product dropped into the part of the Feeder too close to the pump	Follow the instructions in point F.6
	The product is too dry; feeder loading too fast	Add liquid and/or compressed air or nitrogen by means of the small fitting located in the delivery fitting; dose the product while it is being dropped into the feeder, in the initial part of the conveyor screw.
	Excessively worn tubular element	Replace the tubular element of the associated pump (see the relevant manual)
ELECTRICAL MOTOR OVERHEATING: CHECK THE POWER CONSUMPTION ON THE THREE PHASES AND COMPARE IT WITH THE MOTOR'S PLATE VALUES	Excessive delivery pressure; product is possibly very dry	Add liquid and/or compressed air or nitrogen using the small fitting placed in the delivery fitting; slow down the revolutions of the pump/feeder.
	Mains voltage drop or phase imbalance.	Contact an electrician. Contact your electrical service provider
	Insufficient ventilation	Check that the area around the motor is suitable for proper ventilation, free from dirt and foreign bodies. Check the fan.
NOISE AND THROBS INSIDE THE PUMP	Restrictions or obstructions in the suction line due to foreign bodies	Let the pump and feeder run in reverse and start again. Check the suction of the tubular element and replace if necessary. If the problem persists, carry out a check
THE PUMP SHOWS AN ANOMALOUS OPERATION	---	Refer to the pump manual.

In case of problems not described above, contact the Technical Service of Ragazzini S.r.l.

I MAINTENANCE

I.1 GENERAL WARNINGS

<p>WARNING: Maintenance technicians must carry out exclusively the maintenance operations described in this chapter. Supervisors and machine maintenance personnel must comply with the prescriptions issued by the Safety Authorities and must also perform all the specific operations listed in this chapter.</p>	
---	---

<p>NOTE: All the information on maintenance concerns solely and exclusively routine maintenance with actions designed to ensure correct daily operation of the machine. If extraordinary maintenance operations are required, contact Ragazzini S.r.l., which will provide specific information.</p>	
---	---

- The operations for machine set-up and adjustments must be performed by one person only, under the supervision of the maintenance Supervisor.
- Untrained or unauthorised personnel must not enter the machine working area when the machine is under maintenance.
- Maintenance operations must be carried out in adequate lighting conditions; in case of maintenance work to be carried out in areas with insufficient lighting, use portable worklights; take care to avoid areas of shadow that prevent or reduce visibility on the point in which the work must be performed or on the surrounding areas.

I.2 Precautions and warnings when preparing the machine for routine maintenance.

The maintenance technician must:

- Be aware that there may be hazards in carrying out these operations.
- Comply with all the warnings shown on the machine, on the diagrams, in this document and in the attached documentation to avoid faults that in turn could directly or indirectly cause serious accidents, injuries to persons or damage to property.
- Use the personal protective equipment described in the following paragraph.
- Avoid physical contact with the moving parts of the machine.





The operator must also take into account the following:

<p>ELECTROCUTION HAZARD: Maintenance operations that require the presence of electrical power, such as troubleshooting in the electrical panel, must be performed solely and exclusively by expert personnel, according to the safety procedures in force on the premises in which the machine is installed.</p>	
---	---

<p>WARNING: Any technical modification affecting the operation or safety of the machine must be carried out exclusively by the manufacturer’s technical personnel or by technicians formally authorised by the manufacturer. Failure to observe this recommendation exonerates Ragazzini S.r.l. from all responsibility concerning the resulting alterations or any consequent damage. The guards and safety devices may be fully or partly removed during maintenance operations exclusively by expert and/or authorised personnel, who must ensure that all removed safety devices/guards are duly refitted in their original position as soon as maintenance operations have been completed. The machine must not be started up after maintenance operations have been performed until the guards and other safety protections have been refitted.</p>	
--	---

I.3 PERSONAL PROTECTIVE EQUIPMENT

The operator responsible for the maintenance procedure of the feeder must use the following personal protective equipment:

Pictogram	Description	Note
	FOOTWEAR	Use of safety shoes to avoid the risks generated by falling materials.
	PROTECTIVE GLOVES	Gloves for hand protection available in case of manipulation of objects that can cause damage or injuries.
	HELMET	Protective helmet to be used during machine hoisting operations to prevent the dangers generated by hanging loads.
	SUITABLE CLOTHING	Suitable clothing, such as overalls: it is prohibited to wear wide sleeves and/or loosen clothing that could be easily caught in mechanical parts.
	PROTECTIVE FACE SHIELD	Face shield to be used when working on electrical parts, especially when live

WARNING: The machine does not exceed the noise level established by law; therefore, hearing protection earmuffs are not mandatory. However, the operator must also carefully evaluate the environment of use: if it is very noisy, protective earmuffs must be used. When using protective earmuffs, the operator must pay even more attention, as one of the senses of perception of danger (hearing) is missing. Observe the surrounding environment well, as the visual perception must compensate for the lacking sense of hearing.



I.4 PROCEDURES FOR PLACING THE MACHINE IN MAINTENANCE STATUS

Proceed as follows:

- Complete the working cycle in progress.
- Stop the machine.
- Disconnect the electrical supply.
- Fence off the machine and display a “MAINTENANCE IN PROGRESS” sign.

WARNING: Any maintenance work performed on the feeder must be carried out with the machine stopped and disconnected from the electrical supply.



WARNING: NO ACCESS TO UNAUTHORIZED PERSONNEL
Do not allow unauthorised persons to approach the machine when maintenance is in progress. Display warning signs next to the disconnecting switches to inform personnel that the machine is stopped for maintenance, in order to limit the risk of accidental and hazardous manoeuvres.



I.5 NORMAL WEAR PARTS

The only part subject to wear inside the feeder is the seal between the drive shaft and the tank.

WARNING:

Before replacing the component, check if the leak is due to dirt or wear.



I.5.1 REPLACEMENT OF THE SEAL

- Separate the Feeder from the pump.
- Unscrew the screws (1) and remove the feeder entrance (2) taking care not to damage the O-Ring (3).
- Remove the cover of the gearbox (4).
- Unscrew the screw (5) and remove the SCHNORR washer (6).
- Remove the feeder screw (7).

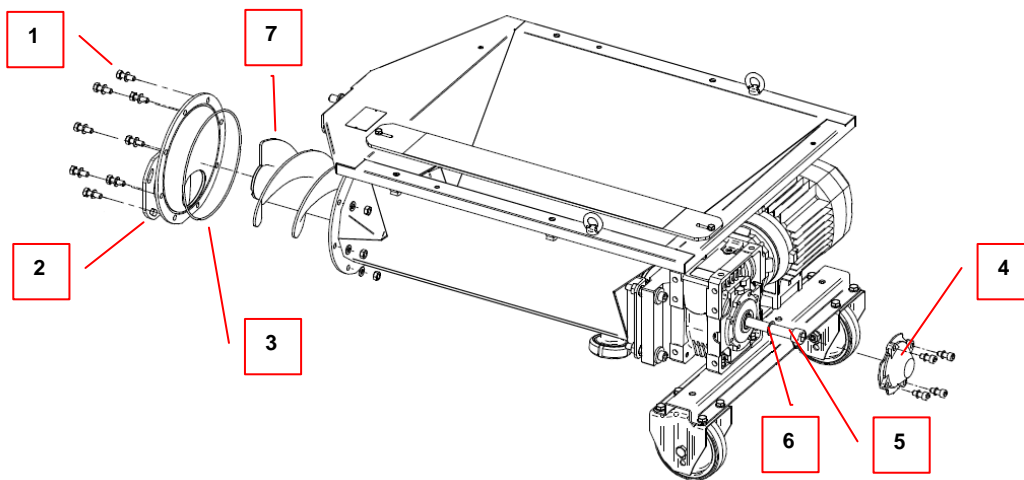

WARNING:

Do not loosen or disassemble the other screws in order not to compromise the position of the feeder screw with respect to the tank; restoring the position would require adjusting a higher number of screws, which would increase the servicing time. Any misalignment of the seal compromises its function and duration.



- To remove the seal to be replaced, make a dent in the point indicated in the figure and extract the component.
- Clean the parts of the seat from any encrustations. Avoid scratching the area of the shaft which guarantees the hydraulic sealing.

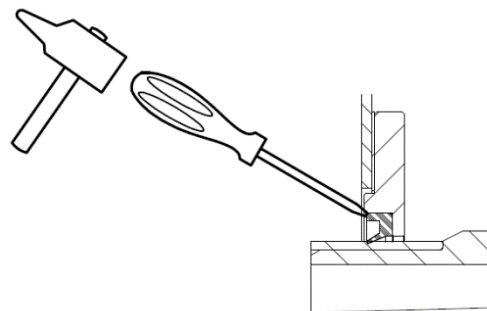

Assembly of the new seal:

- Take the new seal (8), grease it with Rotho silicone grease (supplied with the pump) in order to decrease friction on the seat.
- Comply with the orientation of the lip and place the component by hand, by pressing it with your fingers. Complete the insertion of the component with the help of the tool (9) and a hammer.

NOTE: the tool (9) is available on request as an optional accessory for fitting the seal. It also allows checking and re-centering the shaft with respect to the seal seat.

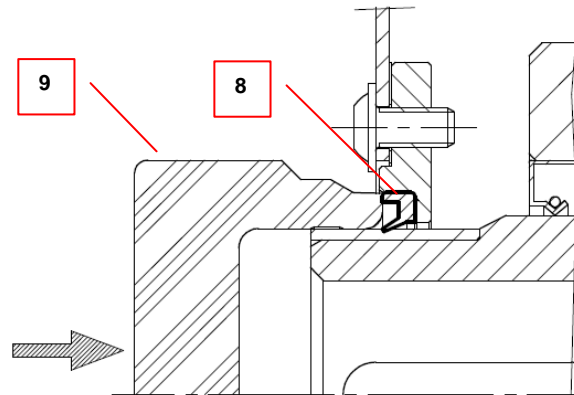

- Be very careful to avoid pressing or straining on the seal lip as it may bend or cut.
- Check that the seal is correctly fitted, against the bottom and that the lip is in contact with its entire perimeter.
- Reassemble the other parts in reverse order, with the following precautions.

WARNING:

Grease the feeder screw (7) at its end with a coupling protector.
 To facilitate subsequent maintenance, grease the thread of the screw (5) with anti-seize grease and assemble using an anti-loosening washer (6).
 Pay attention to the O-Ring (3) which could come out of its seat during the assembly of the inlet connection (2); to facilitate the operation grease the O-Ring with Rotho silicone grease.



I.6 GEARBOX

For routine and extraordinary maintenance of the gearbox, comply with the procedures described on the installed gearbox manufacturer's website.



I.7 MOTOR

For routine and extraordinary maintenance of the motor, comply with the procedures described on the installed motor manufacturer's website.

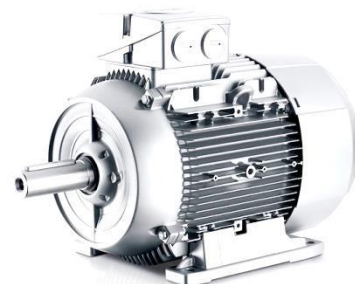

J SPARE PARTS

J.1 HOW TO ORDER SPARE PARTS

To avoid misunderstandings and/or shipment of parts that are unsuitable for the intended purpose, include the following identification data in your request of original spare parts:

- Feeder model.
- Feeder serial number.
- Article code.
- Article description.
- Quantity.
- Type of shipment required.

The identification plate shown here is applied on the feeder.

The information on the plate is necessary for identification of the feeder.

- A. Feeder model.
- B. Serial number.
- C. CE conformity marking.



J.2 SPARE PARTS ORDER EXAMPLE

Feeder model: TR_MS3

Feeder serial number: XXXXXX

Code	Designation	Quantity
A7002505A	REAR WHEEL SUPPORT TR A20	N° 1
GHNP100A1	WHEEL PLS/PLS_____	N° 2

Type of shipment required: Courier: YYYYYY

J.3 SPARE PARTS LIST

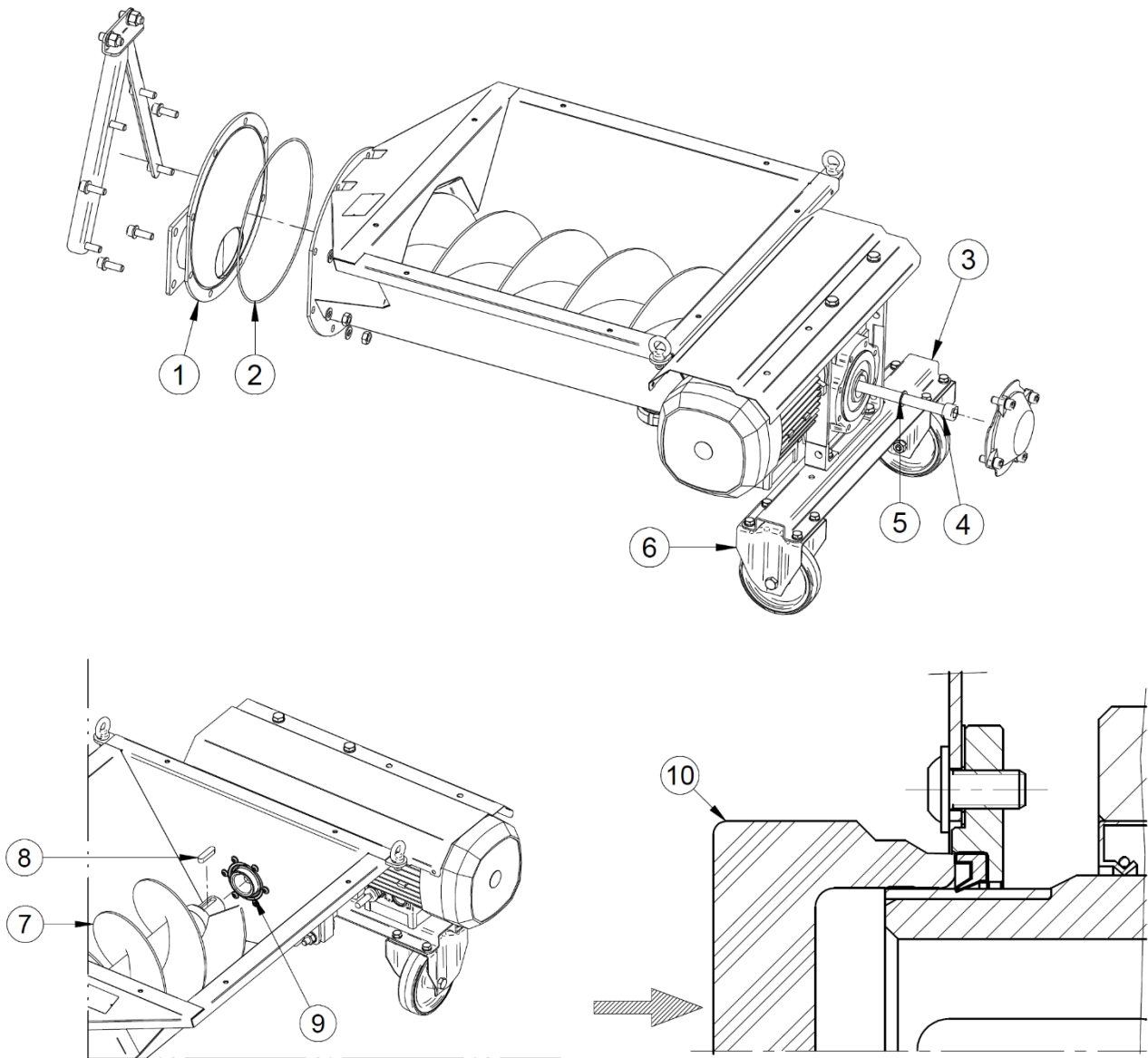

Pos	Description	Q.ty	Code
1	MS3 FEEDER -ENTRANCE-	1	A5002503A
2	O RING d250 T3	1	GR00M0002
3	REAR WHEEL SUPPORT -FEEDER A20-	1	A7002505A
4	SCREW ZN M16	1	S53L20000
5	SCHNORR WASHER D16	1	SR20S1600
6	WHEEL d100 SS SUPP	2	GHNP100A1
7	A20 FEEDER LEFT SCREW	1	A1012500A
8	KEY 40A	1	GL010040B
9	OIL SEAL D62	1	GUGG50062
10	FEEDER SEAL TOOL (OPTIONAL)	1	AT000001A

For parts that do not appear in the list, contact **ragazzini** S.r.l.

K DEMOLITION AND DISPOSAL

K.1 GENERAL WARNINGS CONCERNING DEMOLITION AND DISPOSAL OF THE MACHINE





K.1.1 Special and hazardous waste

- Special waste means residues deriving from industrial processes, materials from the demolition of machines and of deteriorated and obsolete equipment.
- Hazardous waste is waste generated by production activities and containing a significant quantity of pollutants.

<p>WARNING: Disposal of special waste and hazardous waste must be carried out in compliance with statutory legislation. For Italy see Legislative Decree D.lgs 3/4/2006 n. 152, modified by Legislative Decree D.lgs. 3/12/2010, no. 205 and subsequent amendments and additions (“Provisions implementing directive 2008/98/EC”).</p>	
---	---

K.2 PERSONAL PROTECTIVE EQUIPMENT REQUIRED DURING MACHINE DEMOLITION AND DISPOSAL

The operator responsible for the demolition and disposal operations must use the following personal protective equipment:

Pictogram	Description	Note
	FOOTWEAR	Use of safety shoes to avoid the risks generated by falling materials.
	PROTECTIVE GLOVES	Gloves for hand protection available in case of manipulation of objects that can cause damage or injuries.
	HELMET	Protective helmet to be used during machine hoisting operations to prevent the dangers generated by hanging loads.
	SUITABLE CLOTHING	Suitable clothing, such as overalls: it is prohibited to wear wide sleeves and/or loosen clothing that could be easily caught in mechanical parts.

K.3 MACHINE DISMANTLING

The qualified and authorised operator responsible for dismantling the machine must:

- For all the required procedures make use of the PPE shown in the above paragraph (K.2).
- Create sufficient space around the machine to perform all movements without risks for persons.
- Disconnect the power supply disconnectors of the machine and lock them in OFF position.
- Disconnect the connection cable from the socket on the associated pump panel.
- Only after performing all the above activities, proceed to dismantle the machine, working from top down and paying special attention to machine parts/units that may fall due to gravity and all components that may contain product residues.

K.4 SORTING THE MATERIALS

After dismantling the machine in accordance with the above indicated procedure, the various materials must be sorted by type:

- Remove the various machine parts from the working area, taking all the necessary precautions.
- Before lifting very large parts, check that the lifting devices are correctly secured and use exclusively adequate harnesses and lifting tackle.
- Sort the various components by type, as far as possible. The parts should be sorted according to material type (plastic, metal, etc.) and then discarded through waste sorting. The parts resulting from the demolition of the machine should be consigned to an authorised waste sorting agency.

HANGING LOADS HAZARD:

Pay the utmost attention when lifting parts of the machine during demolition.



K.5 DISPOSING OF MACHINE MATERIALS AND PRODUCTS

The machine is made of non-hazardous materials, primarily: stainless steel, iron, aluminium, cast iron, copper, plastic and rubber.

These materials are not subject to degradation such as to constitute a risk for operators.

All electrical and electronic components are purchased by Ragazzini S.r.l. and have already been certified in compliance with Directive 2011/65/EU (RoHS) by their respective manufacturers.

The materials used to protect the machine during transport must be recycled or discarded in compliance with statutory legislation in the destination Country.



Pay attention to the symbol

Disposal must be entrusted to specialised agencies.

L OPTIONAL EQUIPMENT OF THE FEEDER

The following optional equipment/accessories can be supplied on request:

- Collection extension.
- Front wheels kit.
- Exhaust manifold.
- Exhaust valves



RAGAZZINI SRL – Via A. Volta n.8 48018 Faenza (RA) Italy
Tel: +39-0546-620433 – Fax: +39-0546-621394
Email: rotho@ragazzini.it – Web: www.ragazzini.it

